

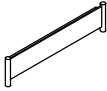



# ASSEMBLY INSTRUCTIONS



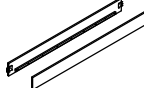

**B1248-115 LENNOX 6/6-6/0 EK/WK HEADBOARD, FOOTBOARD & SLAT KIT**  
**B1248-335 LENNOX 5/0-6/6 EK/Q PANEL SIDE RAILS**

Thank you for purchasing this quality product. Be sure to check all packing materials carefully for small parts, which may have come loose inside the carton during shipment. Identify and count all items and compare with the parts list and/or hardware list shown.

## PARTS LIST

NO	COMPONENT	DRAWING	QTY
A	Headboard		1 pc
B	Footboard		1 pc
C	Right Side Facing (RSF) Headboard Leg		1 pc
D	Left Side Facing (LSF) Headboard Leg		1 pc
E	Slat		5 pcs
F	Slat Support Leg		10 pcs
G	Rail		2 pcs

## HARDWARE LIST

NO	COMPONENT	DRAWING	QTY
1	Bolt M6 X 1 3/8"		6
2	Spring Washer Ø 1/4"		6
3	Flat Washer Ø 1/4" x 1/2"		6
4	Allen Key M4 x 2 9/16"		1
5	CSK Screw M4 x 1 1/4"		10

WEIGHT CAPACITY

800 LBS

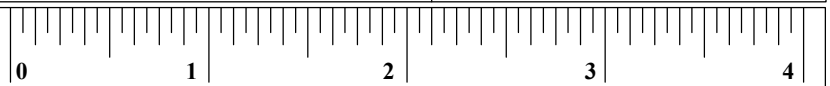

**STEP 1 :** Assemble the Headboard Legs (C & D) to the Headboard (A) by using the Allen Key (4) with hardware 1, 2, and 3.

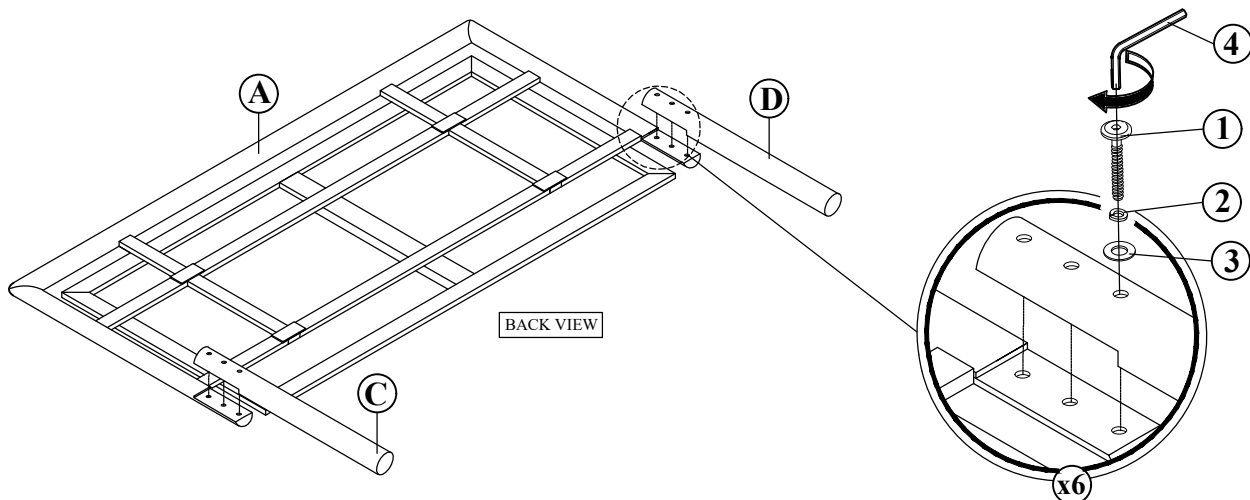

**STEP 2 :** Hook the Side Rails (G) on the iron pins in the Headboard Legs (C & D).Then repeat to hook the other end of Side Rail (G) on the iron pins in the Footboard (B).

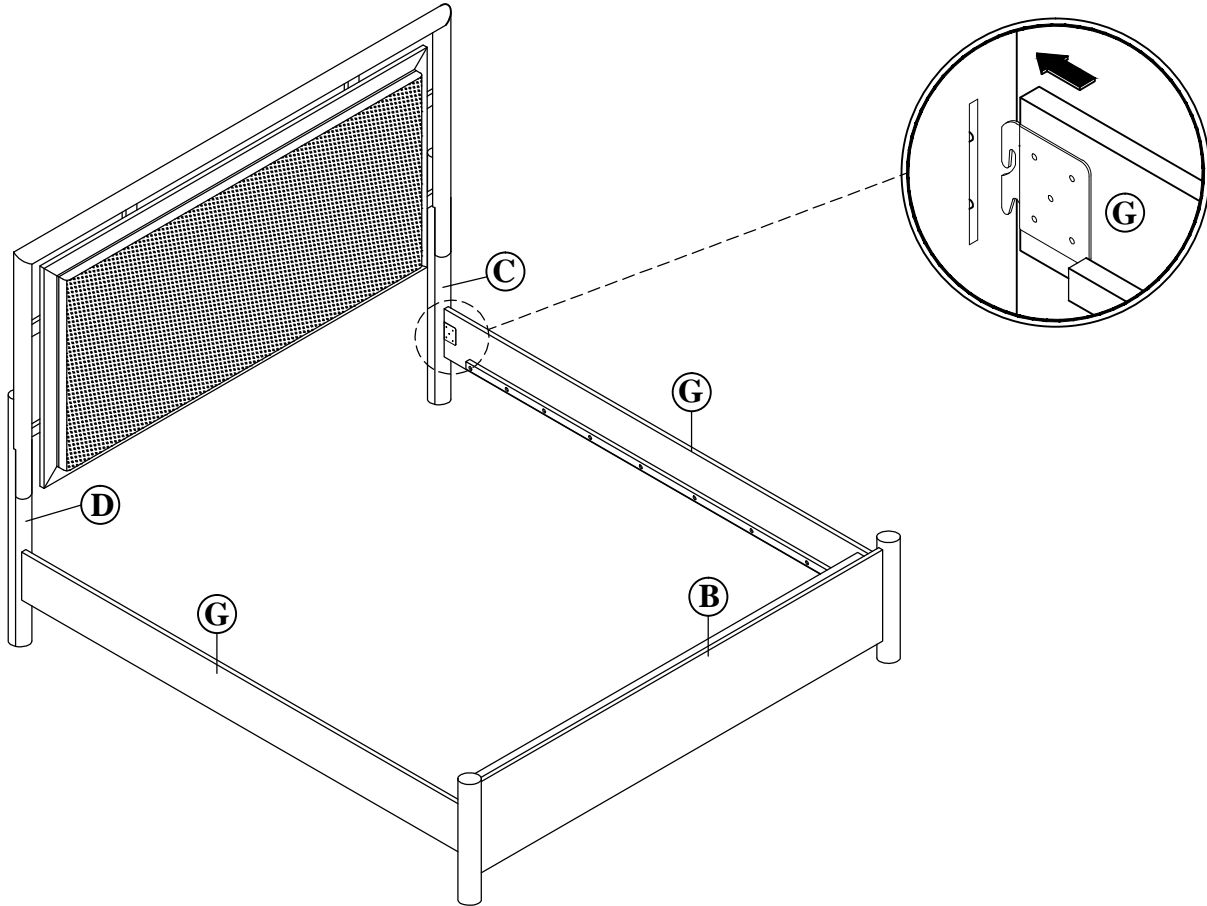

**STEP 3 :** Assemble the Slat Support Legs (F ) to the Slats (E).

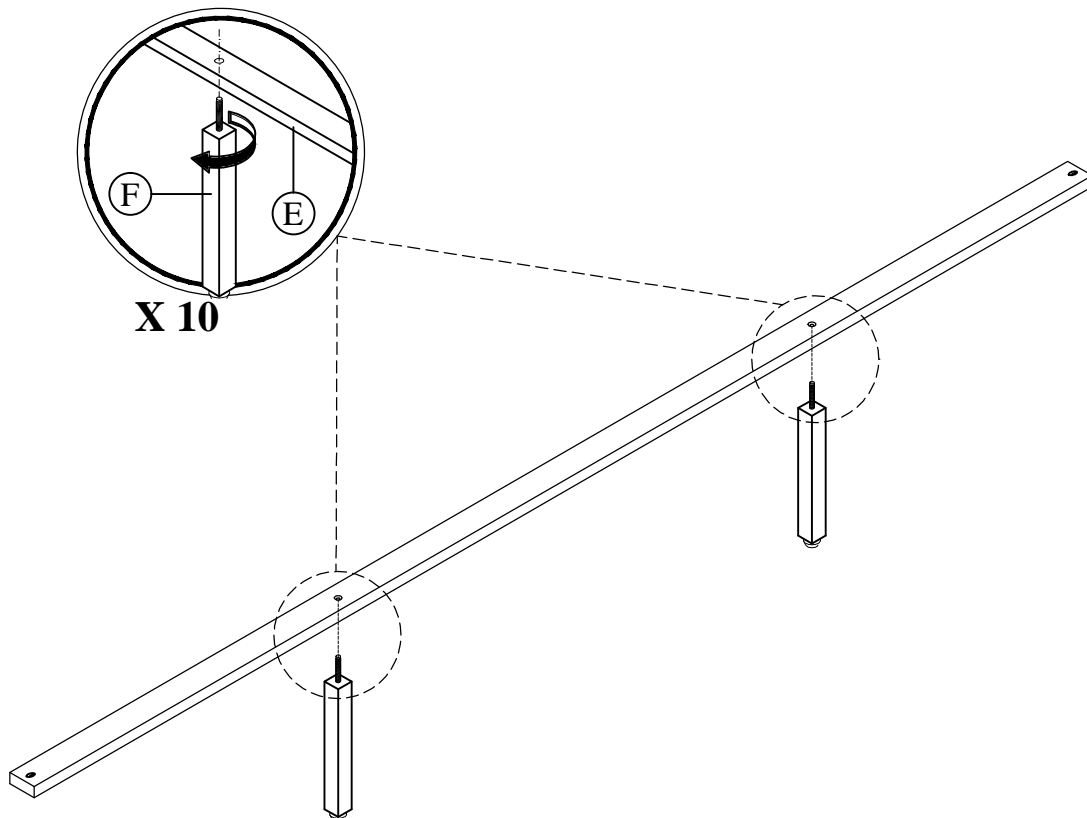

**STEP 4 :** Assemble the Slats (E) to Rails (G) by using a screwdriver with hardware 5.

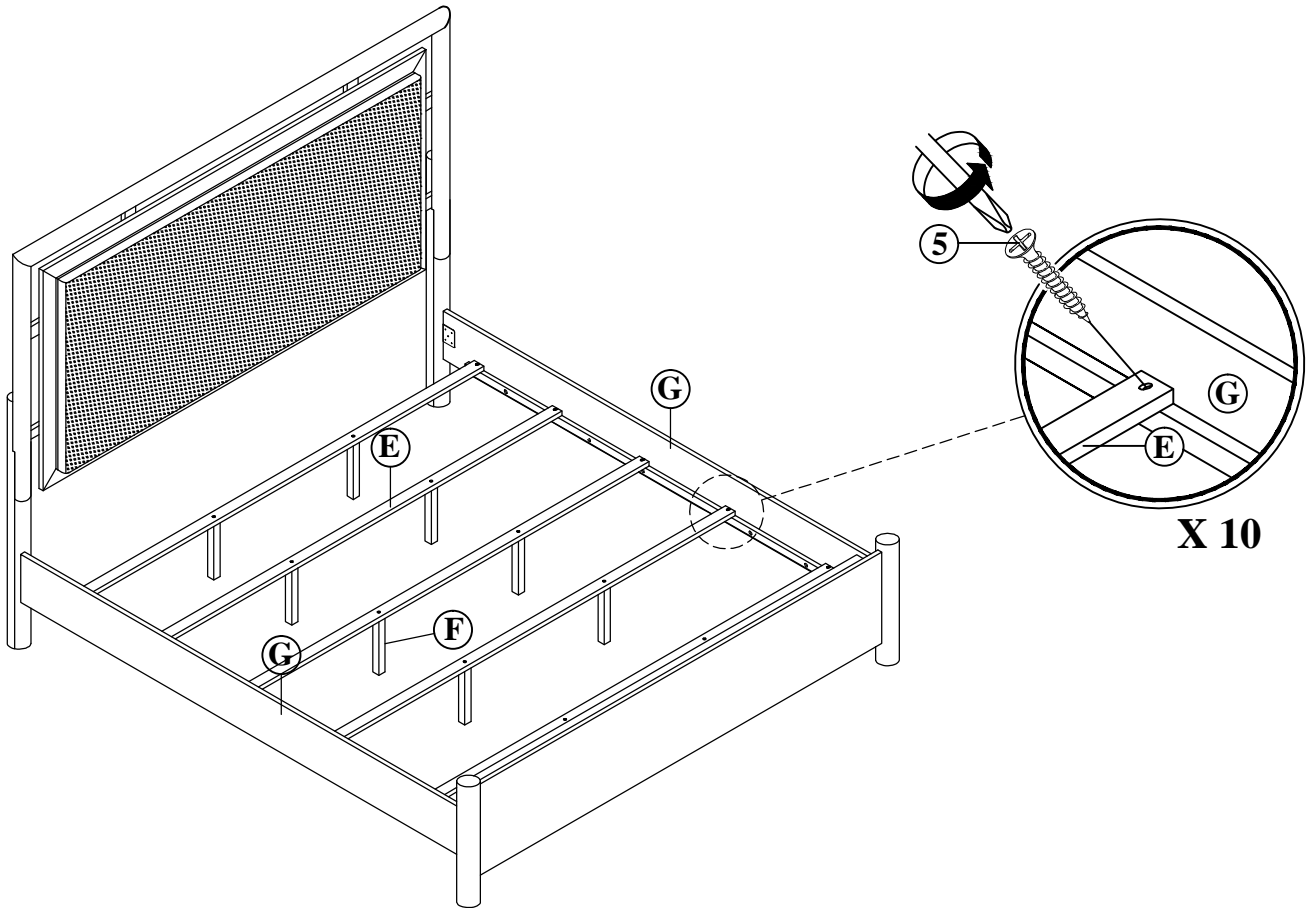

**STEP 5 :** Adjust the leveler on the Slat Support Legs (F) to level the bed.

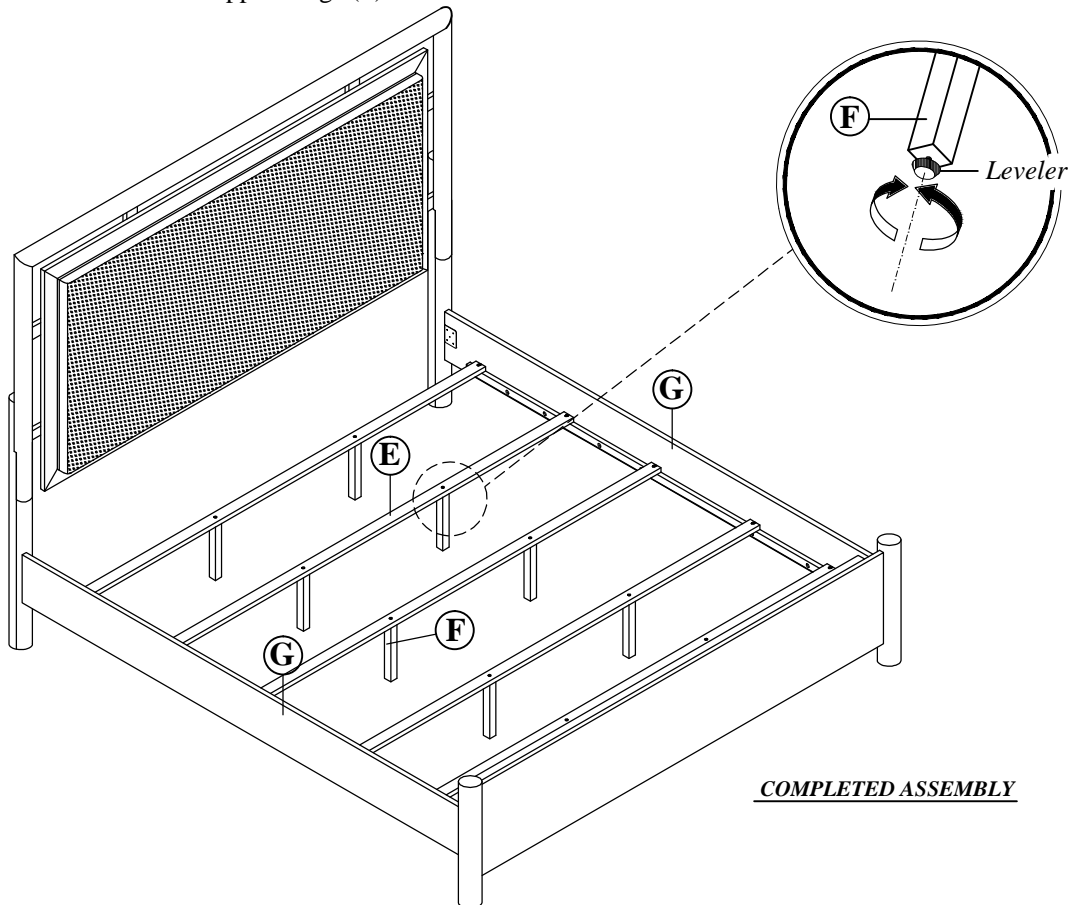

**NOTE :** MUST TIGHTEN SCREWS PERIODCALLY WITH USE SCREW WILL BECOME LOOSE CHECK TIGHTNESS OF ALL SCREW EVERY 6-8 WEEKS.